



When you want Quality, specify COLMAC!



**Installation, Operation,
and Maintenance**
ENG00014424 Rev D

Unit Coolers

Contents

| | |
|------------------------------------|----|
| 1. SAFETY INSTRUCTIONS | 0 |
| 2. INSTALLATION | 2 |
| 3. PIPING..... | 3 |
| 4. ELECTRICAL..... | 8 |
| 5. GENERAL OPERATION..... | 8 |
| 6. HOT GAS DEFROST OPERATION..... | 8 |
| 7. WATER DEFROST OPERATION..... | 11 |
| 8. ELECTRIC DEFROST OPERATION..... | 12 |
| 9. AIR DEFROST OPERATION..... | 13 |
| 10. EMERGENCY SITUATIONS..... | 13 |
| 11. MAINTENANCE | 13 |

1. SAFETY INSTRUCTIONS

To avoid serious personal injury, accidental death, or major property damage, read and follow all safety instructions in the manual and on the equipment. Maintain all safety labels in good condition. If necessary, replace labels using the provided part numbers.



This is the safety alert symbol. It is used to alert you to potential personal injury hazards. Obey all safety messages that follow this symbol to avoid possible injury or death.



DANGER indicates a hazardous situation which, if not avoided, will result in death or serious injury.



WARNING indicates a hazardous situation which, if not avoided, could result in death or serious injury.



CAUTION indicates a hazardous situation which, if not avoided, could result in minor or moderate injury.



NOTICE indicates instructions that pertain to safe equipment operation. Failure to follow these instructions could result in equipment damage.

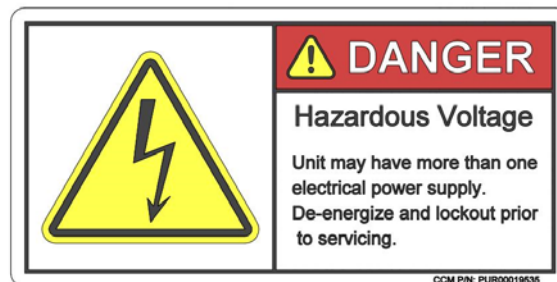

PUR00019535

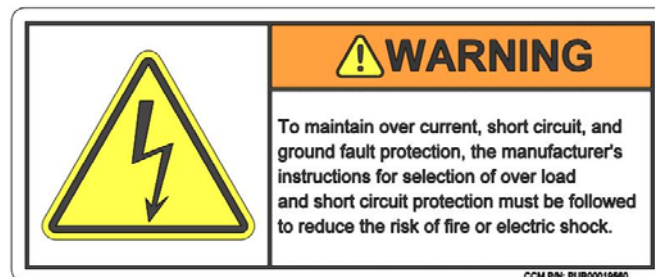

PUR00019560

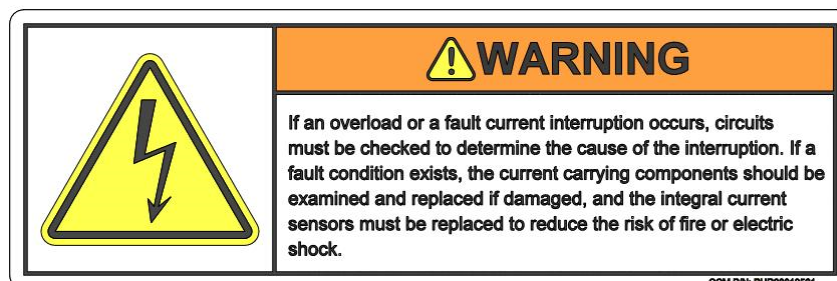

PUR00019561

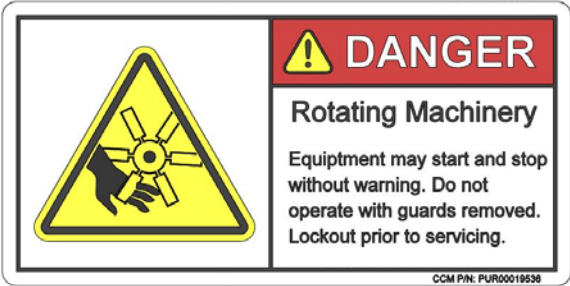

PUR00019536



PUR00019634



PUR00019628



PUR00019562

2. INSTALLATION

2.1. Inspection

- 2.1.1. Damage or Shortage – Upon receipt of equipment, inspect for shortages and damage. Any shortage or damage found during initial inspection should be noted on delivery receipt. This action notifies the carrier that you intend to file a claim. Any damaged equipment is the responsibility of the carrier, and should not be returned to Colmac Coil without prior notification. If any shortage or damage is discovered after unpacking the unit, call the deliverer for a concealed damage or shortage inspection. The inspector will need related paperwork, delivery receipt, and any information indicating his liability for the damage.
- 2.1.2. Specified Equipment – Check unit nameplate for: Electrical specifications to ensure compatibility with electrical power supply. Model Nomenclature and other information to match original order.

2.2. Location

- 2.2.1. For best placement, units should be located in the room opposite the doors, or placed in such a way that air from open doors cannot be drawn directly into the evaporator coil. Colmac recommends against the placement of units directly over doorways. If no alternative exists except placement over doorways, steps must be taken to restrict air infiltration and mitigate dockside moisture.
- 2.2.2. Side clearances for access into service compartments should be 36" minimum. Bottom clearance for removal of drain pan should also be 36" minimum. For units with removable panels for coil cleaning, clearances should be greater for ease of access and ladder placement.
- 2.2.3. The unit(s) should be located so that the air pattern covers the entire room.
- 2.2.4. Minimize refrigerant pipe runs relative to the compressors. Minimize drain line runs.

2.3. Transporting, Storing, Mounting & Rigging

- 2.3.1. Store unit in a clean, dry area, away from traffic and congestion that could cause damage.
- 2.3.2. Use shipping container and forklift to transport unit from truck to storage area and from storage area to installation area. See Submittal drawing for weight of unit. Center of gravity is for all practical purposes the same as the physical center of the unit.
- 2.3.3. Unit is designed to be hung from threaded rods suspended from the ceiling structure. Care must be taken to ensure that the ceiling structure is adequately strong to support the weight of the unit(s). Each unit has hangers to accept two threaded rods at each end of the unit, and two between each fan bay. A rod must be used for each hanger. The installer must ensure that the size of the rod used is adequate to support the unit for any local conditions (seismic, etc.). In some cases, additional hanger bracing may be required.
- 2.3.4. **NOTICE: Use shipping container, or use hangers to lift unit into mounting position. Never lift unit by placing forklift in direct contact with drainpan.**

2.3.5. **CAUTION: Where the finned surface of the coil is exposed, extreme care should be taken to avoid contact with the sharp edges of the fins to minimize the chance of injury.**

2.3.6. The units must be mounted level for proper performance and refrigeration oil return. (Drainpans should be pitched toward drain connections) See Figures 1, 2, 3, and 4 for details.

2.4. Defrost Selection

2.4.1. Determination of defrost should be based on several variables. Energy costs, availability of sufficient supply of water or hot gas, system first cost considerations, and last but not least, the refrigerated spaces operating temperature. Air defrost can certainly not be applied in cold storage applications with temperatures below 40°F. Likewise, the use of a hot gas system in a +42°F (5.6°C) room may be overkill. Table 1 shows recommended guidelines for defrost system selection relative to refrigerated room temperature.

**Table 1
Recommended Room Temperature Ranges for Different Defrost Types**

| Temperature Range | Hot Gas Defrost | Water Defrost | Electric Defrost | Air Defrost |
|--|-----------------|---------------|------------------|-------------|
| Low Temp (<20°F [-6.7°C]) | YES | NO | YES | NO |
| Medium Temp (<40°F and >20°F [-6.7°C]) | YES | YES | YES | NO |
| High Temp (>40°F [7.2°C]) | N/A | N/A | N/A | YES |

3. PIPING

3.1. Refrigerant Piping

3.1.1. Ammonia

- Install all refrigeration and piping components in accordance with the IAR Ammonia Refrigeration Piping Handbook and other applicable local and national codes. Piping practices for ammonia are also described in the “System Practices for Ammonia Refrigerant” chapter in the ASHRAE Refrigeration Handbook.
- Standard coil connections are aluminum flanges supplied with dielectric bushings, gasket, bolts, and mating steel socket weld flanges. For maintaining leak-free joints, be sure to support supply and return piping independent of the coil and re-assemble dielectric flange unions as shown in Figure 9. Always re-check flanges for tightness prior to system startup.
- Units equipped with bimetallic coupling connections can be welded directly to system piping after removal of the factory welded cap. Remove cap so that at least 4” of the connection stub remains. Do not weld within 4” of the bimetallic coupler (see Figure 10).

Note: Evaporators with liquid feed orifices for liquid overfeed must have liquid refrigerant supplied to the coil inlet at a pressure 5 psig (35 kPa) above saturated suction pressure, and at a temperature not exceeding 30°F (-1.1°C) above saturated suction temperature. Please consult factory if conditions exceed the afore mentioned recommendations.

3.1.2. Halocarbon

- Use good practices as described in the “System Practices for Halocarbon Refrigerants” chapter in the ASHRAE Refrigeration Handbook, or other industry publications. Standard coil connections are copper “sweat” connections.

3.2. Hot Gas Defrost Piping

- 3.2.1. With this method of defrost, some of the hot discharge gas from the compressor is routed into the evaporator instead of the condenser. During hot gas defrost, the coil temperature should be high enough to melt frost and ice on the coil, but low enough so that heat and steam loss to the refrigerated space are minimized.
- 3.2.2. Only 1/3 of the evaporators in a system should be defrosted at one time. Example: if total evaporator capacity is 100 tons (352 kW), then evaporators with no more than 33 tons (116 kW) of capacity should be defrosted at once. Consult factory if your system does not permit this.
- 3.2.3. Suggested methods of piping can be seen in Figure 11 thru 14. To maintain uninterrupted gas flow and a clear, fully drainable condensing surface, hot gas is always fed through the evaporator from the top down. For a bottom feed coil, this involves feeding the suction header with hot gas, as is seen in Figure 11. For a top feed coil, like in a Top Feed Recirculated or a Direct Expansion evaporator, the liquid header/distributor is fed with hot gas. This can be seen in Figure 12 for Top Feed Recirculated and in Figure 13 for Direct Expansion. Figure 14 shows hot gas piping for gravity flooded evaporators.
- 3.2.4. Colmac Coil recommends the use of forward-cycle for hot gas defrost. With this method, hot gas is piped in series through the unit cooler, first through the hot gas drainpan loop, and then through the coil. This method requires the use of a third line to the air unit to supply hot gas. All of the piping diagrams mentioned in the previous paragraph show a forward-cycle implementation. Consult the Factory for information regarding reverse-cycle hot gas defrost.
- 3.2.5. For evaporators with cooling capacity 15 tons and greater, a soft start solenoid valve is recommended (See Figures 11 through 14). Soft Start uses a secondary, smaller solenoid capable of letting a reduced amount of hot gas into the defrost system at the beginning of defrost, while the main hot gas solenoid remains closed. Once the system is up to a pre-designated pressure (~40 psig), the main hot gas solenoid is opened, allowing the system to approach its normal operating pressure. The Soft Start system eases the unit cooler into the defrost cycle, limiting unwanted problems like check valve chatter, pipe movements, and most of all, liquid hammer. This control method is particularly useful on larger systems.
- 3.2.6. All hot gas piping located in cold spaces should be insulated, as well as all hot gas piping located outdoors in cold climates.
- 3.2.7. The amount of hot gas supplied will depend on the inlet pressure of the hot gas, and the capacity of the air unit.
- 3.2.8. **Ammonia** - Hot gas is typically supplied to evaporators by one of two methods:
- Install a pressure regulator in the compressor room at the hot gas takeoff. Set the regulator to approximately 100 psig (689.5 kPa), then size the piping to achieve 75 to 85 psig (517 to 586 kPa) condensing pressure at the evaporators, accordingly.

- In branches leading to each evaporator from the main hot gas line, install a pressure regulator set at approximately 75 to 85 psig (517 to 586 kPa), then size the branches accordingly.

3.2.9. **Halocarbon** – Hot gas piping is typically sized to accommodate twice the normal refrigerant mass flow from the evaporator. Pressure drop is not as critical for the Halocarbon defrost cycle, so refrigerant velocity can be used as the criterion for line size. It is suggested that hot gas lines are sized for the refrigerant velocity between 1000 to 2000 ft/min (5 to 10.2 m/s).

3.3. Water Defrost Piping (Supply Water)

3.3.1. Water defrosting consists of distributing water over the coil surface for a very short period of time, then draining the water from the piping before freezing can occur.

3.3.2. Figures 5 thru 8 show the water defrost piping and controls layout for the four different unit cooler configurations. A solenoid valve in the water supply line to one or more defrost units, opens under control of an automatic timer to allow water to the units. Water flow to unit water distribution pans is metered by manually adjusted balancing or globe valves. A length of 1/4 in OD tubing is installed as shown in all of the figures to drain the supply piping when the solenoid valve closes, and the defrost period ends. A slope of 1/2 in per foot is recommended for all supply lines to maintain adequate drainage. All four unit coolers are piped similarly, with the major exception being the LV unit cooler. The LV has two water distribution pans and two drainpans, and as such, requires additional consideration when piping (see Figure 8).

3.3.3. For normal conditions, Table 2 may be used to select water supply sizes. However, if supply water pressure is lower than 30 psig (207 kPa), then the supply piping should be sized larger.

3.3.4. The following procedure should be used when sizing supply water piping:

- Choose a preliminary pipe size from Table 2.
- List the equivalent lengths of all fittings and valves given in Table 3.
- Add the sum of all equivalent lengths, to the lengths of all straight pipe runs.
- Divide the total length from step 3 by 100.
- Obtain the Pressure Loss per 100 feet of pipe from Table 6. Multiply this by the number obtained in Step 4. (This is the pressure loss through the pipe, valves and fittings due to length and flow impedances)
- List the change in elevation (+ is up, - is down) of all vertical pipe runs and determine pressure losses in pipe from the gain in elevation from Table 4. The sum of Step 5, Step 6 plus a 5 psig allowance, is the total pressure loss through pipe valves and fittings, and must not exceed the water pressure in the supply main. If it does exceed supply pressure, recalculate steps 2 through 7 with a larger pipe.

Table 2
Recommended Pipe Size, Water Defrost Supply

| Pipe Size (IPS, inches) | Schedule 40 Steel | | Copper & Plastic | |
|----------------------------|-------------------|---------------|------------------|---------------|
| | GPM | L/s | GPM | L/s |
| 1 | 3 to 7 | (0.2 to 0.4) | 3 to 7 | (0.2 to 0.4) |
| 1-1/4 | 8 to 15 | (0.5 to 0.9) | 8 to 12 | (0.5 to 0.8) |
| 1-1/2 | 15 to 22 | (1.0 to 1.4) | 13 to 20 | (0.9 to 1.3) |
| 2 | 23 to 40 | (1.5 to 2.5) | 21 to 45 | (1.4 to 2.8) |
| 2-1/2 | 41 to 70 | (2.6 to 4.4) | 46 to 80 | (2.9 to 5.0) |
| 3 | 71 to 130 | (4.5 to 8.2) | 81 to 130 | (5.1 to 8.2) |
| 4 | 131 to 250 | (8.3 to 15.8) | 131 to 270 | (8.3 to 17.0) |

* Based on pressure loss of 1 to 4 ft / 100 ft (100 to 400 Pa/m)

Table 3
Equivalent Length of Water Defrost Pipe Fittings, Feet

| Pipe Size, (IPS, inches) | 1 | 1-1/4 | 1-1/2 | 2 | 2-1/2 | 3 | 4 |
|--------------------------|------|-------|-------|------|-------|------|-------|
| Solenoid | 15.0 | 16.0 | 16.0 | 18.0 | 18.0 | 20.0 | -- |
| 90° Elbow | 5.2 | 6.6 | 7.4 | 8.5 | 9.3 | 11.0 | 13.0 |
| Tee | 6.6 | 8.7 | 9.9 | 12.0 | 13.0 | 17.0 | 21.0 |
| Coupling or Gate Valve | 0.8 | 1.1 | 1.2 | 1.5 | 1.7 | 1.9 | 2.5 |
| Globe Valve | 29.0 | 37.0 | 42.0 | 54.0 | 62.0 | 79.0 | 110.0 |
| Angle Valve | 17.0 | 18.0 | 18.0 | 21.0 | 22.0 | 28.0 | 38.0 |

Add equivalent length of all fittings to length of same straight pipe to obtain total length for use on Table 8.

Table 4
Pressure Loss Due to Elevation

| | | | | | | | | | |
|----------------------|---|---|---|----|----|----|----|----|----|
| Elevation, (ft) | 5 | 7 | 9 | 12 | 16 | 23 | 35 | 46 | 60 |
| Pressure Loss, (psi) | 2 | 3 | 4 | 5 | 7 | 10 | 15 | 20 | 26 |

Table 5
Water Defrost
Recommended Drain Line Sizes

| | | | | | | | | |
|--------------------------|----|-----|----|-----|----|-----|-----|-----|
| Water Flow, (GPM) | 15 | 25 | 42 | 63 | 89 | 170 | 275 | 550 |
| Pipe Size, (IPS, inches) | 2 | 2.5 | 3 | 3.5 | 4 | 5 | 6 | 8 |

**Table 6
Water Capacity, GPM
Sch 40 Pipe**

| Pipe Size (IPS, Inches) | Pressure Loss Per 100 ft, psi | | | | | | |
|----------------------------|-------------------------------|-------|-------|-------|-------|-------|------|
| | 2 | 5 | 10 | 15 | 20 | 30 | 50 |
| 1 | 8 | 12.8 | 19.1 | 24 | 27.8 | 33.9 | 44.5 |
| 1-1/4 | 17.4 | 26.9 | 29.7 | 49.5 | 57.4 | 70 | 91.9 |
| 1-1/2 | 25.9 | 41 | 60 | 74.1 | 85.5 | 106.5 | 140 |
| 2 | 51.4 | 79.6 | 116.7 | 144.7 | 166.9 | 203.2 | 268 |
| 2-1/2 | 80.9 | 127.6 | 186 | 229 | 264.6 | 330.8 | 390 |
| 3 | 144.3 | 227.6 | 331.6 | 407.2 | 467.7 | 575.4 | -- |
| 4 | 292 | 469.6 | 671.8 | 826.8 | 961.7 | -- | -- |

** For SCH 40 steel pipe. Multiply psig values by 0.86 for PVC or Copper Pipe.

Notes:

- If the water supply pressure is unknown, it may be measured by installing a gauge and valve at the “takeoff” point. The pressure should be measured with water flowing near the desired rate.
- In some instances, (as with 2” pipe), it may be desirable to use a solenoid valve to fit the next size smaller pipe. (As with all valves and fittings, determine the correct equivalent length to calculate pressure loss)

3.4. Defrost Drain Piping

3.4.1. Drain connections from the drainpan should be individually trapped. Individual trapping prevents warm air from being drawn back through the drain pipe of non-defrosting units. Drain line size should be at least equivalent to the unit cooler drain connection size. See Figures 5, 6, 7, and 8 for details. For Water Defrost, use Table 5 for sizing defrost drain line sizes.

3.4.2. Within the refrigerated space, the drain line should be pitched sharply down, at least 1/2 in/ft (4 cm/m) and be as short as possible. It should also be insulated along its entire length. Traps should be located in a warm area outside the refrigerated space. Any traps or extensive lengths of pipe located outdoors must be heated and insulated to prevent freeze up. Any such heater should be connected for continuous operation. Standard industry practice is for 20 Watts / linear foot of pipe @ 0°F (-17.8°C) and 30 Watts / linear foot of pipe @ -20°F (-28.9°C).

3.4.3. Drainpan and drain lines should be inspected routinely for evidence of ice buildup. Periodic manual maintenance of icing drainpans and drain lines may be required if less than ideal frosting/defrosting conditions have existed. See the Troubleshooting chart for information regarding the diagnosis of freezing drainpans and drain lines.

3.5. Connection Sizes

3.5.1. Refrigerant, defrost supply, and defrost drain connection sizes are pre-determined by the factory and the customer. Connection sizes are automatically selected through the use of our proprietary Coldware unit cooler selection software. More information on connection sizing can be found in the ASHRAE Refrigeration Handbook.

4. ELECTRICAL

- 4.1. Standard motors for AR, ICL, and LV air coolers include internal thermal overload protection. Custom motors may require external overload relays.
- 4.2. Standard motors for ICH air coolers do not include thermal overload protection.
- 4.3. Select feeder circuit protection, branch circuit protection, motor contactors, overload relays, and wire sizes in accordance with applicable local and national codes.
- 4.4. Field wiring connections are made to individual motors at connection boxes at each fan bay or at a common electrical enclosure depending on unit type and customer specification. Electrical work should only be performed by qualified personnel.
- 4.5. Basic motor wiring diagrams are shown in Figure 15. Complete electrical controls with a UL Enclosed Industrial Control Panel listing can be provided at the customer's request. Units equipped with electric defrost and/or special electrical controls will be provided with specific wiring diagrams.
- 4.6. Defrost termination and fan delay switches are provided on the return end of the air cooler. Sensing bulbs are factory installed on a refrigerant circuit return bend. The maximum operating temperature for this control device is -30°F.

5. GENERAL OPERATION

5.1. Before Startup

- Make sure unit voltage agrees with supply voltage.
- Make sure system is wired correctly and in accordance with the guidelines laid out in this IOM, as well as local and national standards that may apply.
- Check torque on all electrical connections.
- Make sure all piping is done completely and in accordance with the guidelines laid out in this IOM, as well as in accordance with standard good practice.
- Make sure that liquid supply suction and hot gas supply (as applicable) service valves are open.
- Make sure unit is mounted securely using all hangers, and is level.
- Make sure that all fan set screws are tight.
- Check drainage of drain pan and drain piping by pouring water into drainpan.
- Check water defrost distribution – see “Regulating Water Flow Rate”. (Water Defrost units only)

5.2. After Startup

- Check the compressor for possible overload immediately after start up.
- Check fan rotation of all fans to make sure air is moving in proper direction.
- Check the air unit operation for proper refrigerant charge.
- Heavy moisture loads are usually encountered when starting a system for the first time. This will cause rapid frost buildup on the unit. During the initial pull-down we suggest that the frost buildup be watched and that the unit be defrosted manually as required.

6. HOT GAS DEFROST OPERATION

- 6.1. Condition of Operation - Hot Gas Defrost can be used for any design criteria, including Low-Temp and Medium-Temp.

6.2. Proper hot gas defrost operation is entirely dependent on hot refrigerant latent condensation during the defrost operation. This requires hot gas to be delivered to the evaporator at a saturation pressure necessary for condensation to occur during defrost. Typical design hot gas saturation temperatures run between 50°F (10°C) to 60°F (15.6°C). Table 7 shows the equivalent saturation pressures, for a variety of refrigerants, required at the evaporator to accommodate this temperature range.

**Table 7
Hot Gas Pressures for Various Refrigerants**

| Refrigerant | R22 | Ammonia (R717) | R507a | R404a |
|-------------------------------|--------------------------------------|-------------------------------------|---------------------------------------|---------------------------------------|
| Hot Gas Pressure @ Evaporator | ~85 to 100 psig (~688 to 791 kPa) | ~75 to 90 psig (~619 to 722 kPa) | ~105 to 125 psig (~826 to 964 kPa) | ~105 to 125 psig (~826 to 964 kPa) |

6.3. Hot Gas Supply line pressure should be maintained at less than the system condensing pressure. This serves two purposes; the first being decreased energy losses due to excessive heat gain, and the second being that condensing pressure has a tendency to fluctuate with ambient conditions and with the load. Maintaining the Hot Gas Supply pressure at less than the system condensing pressure helps insure a constant Hot Gas pressure at the evaporator.

6.4. Sequence of Hot Gas Defrost Operation

6.4.1. Recirculated Bottom Feed Evaporators (See Figure 11)

- Close Liquid Solenoid and continue operating fan motors.
- Pump down liquid refrigerant from coil for a period of approximately 15 minutes (or as long as required). Any cold liquid refrigerant remaining in the coil at the beginning of defrost will greatly reduce the effectiveness of the hot gas defrost operation and can extend the time required for defrost. Evidence of residual liquid refrigerant can be seen in the form of uneven melting or the absence of melting on the lower tubes of the evaporator coil.
- Stop fan motors.
- Open Hot Gas Pilot Solenoid to close Gas-Powered Suction Stop Valve.
- On Coils of 15 tons cooling capacity and larger, open Soft Start Hot Gas Solenoid to gradually bring coil up to near defrost pressure.
- Open Hot Gas Solenoid to start defrost. Duration of defrost should be long enough to clear coil and pan. Extending the defrost period longer than this is not necessarily better.
- Close Hot Gas Solenoid (and Soft Start Hot Gas Solenoid if applicable) to end defrost.
- Open Equalizing Bleed Valve to gradually bring evaporator back down to suction pressure.
- Close Hot Gas Pilot Solenoid to open the Gas-Powered Suction Stop Valve. At the same time, open the Liquid Solenoid to start cooling the coil.
- After a delay to refreeze remaining water droplets on the coil, restart the fans.

6.4.2. Recirculated Top Feed and Direct Expansion Evaporators (See Figure 12 and 13)

- Close Liquid Solenoid and continue operating fan motors.

- Pump down liquid refrigerant from coil for a period of approximately 15 minutes (or as long as required). Any cold liquid refrigerant remaining in the coil at the beginning of defrost will greatly reduce the effectiveness of the hot gas defrost operation. Evidence of residual liquid refrigerant can be seen in the form of uneven melting or the absence of melting on the lower tubes of the evaporator coil.
- Stop fan motors.
- Open Hot Gas Pilot Solenoid to close Gas-Powered Suction Stop Valve.
- On Coils of 15 tons cooling capacity and larger, open Soft Start Hot Gas Solenoid to gradually bring coil up to near defrost pressure.
- Open Hot Gas Solenoid to start defrost. Duration of defrost should be long enough to clear coil and pan. Extending the defrost period longer than this is not necessarily better.
- Close Hot Gas Solenoid (and Soft Start Hot Gas Solenoid if applicable) to end defrost.
- Energize the Defrost Relief Regulator to the wide open position to gradually bring the evaporator back down to suction pressure (equalize).
- Close Hot Gas Pilot Solenoid to open the Gas-Powered Suction Stop Valve. At the same time, de-energize the Defrost Regulator Valve.
- Open the Liquid Solenoid to start cooling the coil.
- After a delay to refreeze remaining water droplets on the coil, restart the fans.

6.4.3. Gravity Flooded Evaporators (See Figure 14)

- Close Liquid Solenoid and stop fan motors.
- Open Hot Gas Pilot Solenoid to close the two Gas-Powered Stop Valves in the coil liquid and suction lines.
- On Coils of 15 tons cooling capacity and larger, open Soft Start Hot Gas Solenoid to gradually bring coil up to near defrost pressure.
- Open Hot Gas Solenoid to start defrost. Duration of defrost should be long enough to clear coil and pan. Extending the defrost period longer than this is not necessarily better.
- Close Hot Gas Solenoid (and Soft Start Hot Gas Solenoid if applicable) to end defrost.
- Energize the Defrost Relief Regulator to the wide open position to gradually bring the evaporator back down to suction pressure (equalize).
- Close Hot Gas Pilot Solenoid to open the Gas-Powered Suction Stop Valves. At the same time, de-energize the Defrost Regulator Valve.
- Open the Liquid Solenoid.
- After a delay to refreeze remaining water droplets on the coil, restart the fans.

6.4.4. Setting Hot Gas Defrost Timer. Time periods should be set as follows:

- Length of defrost should be set to the minimum time necessary to melt all frost. Defrost operation beyond this point will convert liquid water to steam, leading to secondary condensation and freezing on non-heated areas of the unit cooler and introduced unwanted heat gain into the controlled space.
- Depending on frost loading conditions, defrost duration can typically last anywhere from 12 to 20 minutes, and in most cases, should never exceed 30 minutes.
- Actual defrost times must be determined from careful observation of defrost operation and adherence to the previously mentioned guidelines. Frost is usually heaviest on the air-entering side of the coil, and inspection of fins on this side can usually be used to determine if complete defrost has occurred.

Periodic observation of the defrost cycle throughout the year is necessary to maintain a properly operating defrost system.

NOTICE: Once frost turns to ice, the amount of time required to melt increases. Incomplete defrosting may allow excessive ice to build up which could damage the machinery. Allowing ice to build up on the fan blades will result in excessive vibration which could lead to catastrophic failure. It is imperative that the end user inspect the unit coolers regularly for proper defrosting. Manual defrosting may be required to remove ice buildup.

7. WATER DEFROST OPERATION

7.1. Condition of Operation - Water Defrost can be used for Medium-Temp and High-Temp installations only, within the range of standard municipal water temperatures. Special considerations may be made for operation at less than Medium-Temp conditions if elevated water temperatures are used. Consult factory for clarification.

7.2. Sequence of Water Defrost Operation

- Stop refrigeration by closing liquid solenoid.
- Pump down liquid refrigerant from coil for a period at least equal to 15 minutes. Any liquid refrigerant that may remain in the coil during defrost will greatly reduce the effectiveness of the hot gas defrost operation. Evidence of residual liquid refrigerant during defrost can be seen in the form of uneven melting or the absence of melting on the lower tubes of the evaporator coil.
- Stop fan motors.
- Open water valve for the necessary time of defrost.
- Allow water to drain from fins.
- Bleed evaporator pressure back down to normal suction pressure.
- Start refrigeration to cool the evaporator.
- Restart fan motors.

7.3. Setting Water Defrost Timer

7.3.1. Instructions for adjustment of Defrost Timer should be shown in the Timer User's Manual.

7.3.2. Time periods should be set as follows:

- The delay period for pump down and fan stoppage is approximately 1 minute. With very large coils where time for pump-down after shutting the refrigerant solenoid valve may be longer, the delay period may be longer. Set the delay accordingly.
- Set the water spray to five minutes, initially. In actual practice, it may take as little as three minutes to clear frost from the coil, and only in rare instances would it take as long as fifteen minutes.
- Actual defrost times must be determined from careful observation of defrost operation and adherence to the previously mentioned guidelines. Frost is usually heaviest on the air-entering side of the coil, and inspection of fins on this side can usually be used to determine if complete defrost has occurred. Periodic observation of the defrost cycle throughout the year is necessary to maintain a properly operating defrost system. If more than fifteen minutes is required to completely remove frost, it is an indication that something may be wrong, such as inadequate water supply.
- Set drain period for two minutes. This should be ample time for water to drain off of the coil before starting up the fans.

- The frequency of defrosting will seldom exceed once per day for storage rooms with average traffic. Small rooms with heavy service may require a defrost cycle twice per day and only in unusual circumstances will more than two be required.

NOTICE: Once frost turns to ice, the amount of time required to melt increases. Incomplete defrosting may allow excessive ice to build up which could damage the machinery. Allowing ice to build up on the fan blades will result in excessive vibration which could lead to catastrophic failure. It is imperative that the end user inspect the unit coolers regularly for proper defrosting. Manual defrosting may be required to remove ice buildup.

7.4. Specifying Water Defrost Temperature

7.4.1. Adequate temperature of the water defrost supply must be maintained throughout the defrost to guarantee adequate defrost under varying room temperature conditions. Recommended water temperatures as a function of room temperature are found in Table 8.

**Table 8
Recommended Water Defrost Temperatures**

| Room Temperature | Water Temperature |
|---------------------------------|-----------------------|
| 20°F to 30°F (-6.7°C to -1.1°C) | At least 50°F (10°C) |
| 30°F to 32°F (-1.1°C to 0°C) | At least 45°F (7.2°C) |
| 32°F (0°C) and up | At least 40°F (4.4°C) |

7.5. Regulating Water Flow Rate

7.5.1. Water flow rate is controlled by adjusting the balancing valve at each unit. Adjust flow rate to fully saturate the coil fin surfaces in defrost water, making sure not to overflow the distribution pan, which can result in undesirable splashing. In some areas, the water pressure may become very low during daytime hours due to usage in the same building or neighborhood. In such instances, it may be necessary to set the timer to defrost when adequate water pressure is available.

8. ELECTRIC DEFROST OPERATION

8.1. Condition of Operation - Electric Defrost can be used for any design criteria, including Low-Temp, Medium-Temp, and High-Temp Applications.

8.2. Sequence of Electric Defrost Operation

- Stop refrigeration by closing liquid solenoid.
- Pump down liquid refrigerant from coil for a period at least equal to 15 minutes. Any liquid refrigerant that may remain in the coil during defrost will greatly reduce the effectiveness of the electric defrost operation. Evidence of residual liquid refrigerant during defrost can be seen in the form of uneven melting or the absence of melting on the lower tubes of the evaporator coil.
- Stop fan motors.
- Energize power to electric defrost heating elements for the necessary time of defrost.
- De-energize power to heating elements when defrost is complete.
- Start refrigeration to cool the evaporator.
- Restart fan motors.

8.3. Setting Electric Defrost Timer - Time periods should be set as follows:

- Length of defrost should be set to the minimum time necessary to melt all frost. Defrost operation beyond this point will convert liquid water to steam, leading to secondary condensation and freezing on non-heated areas of the unit cooler and introduced unwanted heat gain into the controlled space.
- Average defrost times can vary anywhere from fifteen to twenty minutes, and in most cases, should never exceed thirty minutes.
- Actual defrost times must be determined from careful observation of defrost operation and adherence to the previously mentioned guidelines. Frost is usually heaviest on the air-entering side of the coil, and inspection of fins on this side can usually be used to determine if complete defrost has occurred. Periodic observation of the defrost cycle throughout the year is necessary to maintain a properly operating defrost system.

NOTICE: Once frost turns to ice, the amount of time required to melt increases. Incomplete defrosting may allow excessive ice to build up which could damage the machinery. Allowing ice to build up on the fan blades will result in excessive vibration which could lead to catastrophic failure. It is imperative that the end user inspect the unit coolers regularly for proper defrosting. Manual defrosting may be required to remove ice buildup.

9. AIR DEFROST OPERATION

9.1. Condition of Operation - Air Defrost can be used for High-Temp installations only.

9.2. Sequence of Air Defrost Operation

- Pump down liquid refrigerant from coil for a period at least equal to 15 minutes. Any liquid refrigerant that may remain in the coil during defrost will greatly reduce the effectiveness of the air defrost operation. Evidence of residual liquid refrigerant during defrost can be seen in the form of uneven melting or the absence of melting on the lower tubes of the evaporator coil.
- Allow fans to continue operating for the necessary time of defrost.
- Re-introduce refrigerant into evaporator and re-start refrigeration to cool the evaporator.

9.3. Setting Air Defrost Timer

9.3.1. Time periods should be set as follows:

- Time to defrost should be just long enough to melt all frost.

10. EMERGENCY SITUATIONS

10.1. During normal operation the units described in this IOM contain either ammonia or one of several possible halocarbon refrigerants. There are hazards and risks associated with all refrigerants. Refrigerant leaks can cause an emergency situation. Refer to the facility "Emergency Planning Policy" and "Hazardous Chemical Communication Policy" for the proper methods of dealing with any potential emergency situation resulting from a refrigerant leak.

11. MAINTENANCE

11.1. **WARNING: Prior to any maintenance being performed, unit must be locked out and tagged out per the Lockout/Tag Out policy of the facility where installed.**

11.2. System Maintenance Schedule (recommended maximum time periods)

11.2.1. Every month

- Check for proper defrosting and proper defrost timing.*

***The system should be periodically checked for proper defrosting and defrost timing due to variations in the quantity and pattern of frost. Frost accumulation is dependent on the following: temperature of the space, type of product stored, product loading rate, traffic, moisture content of air entering conditioned space, etc. It may be necessary to periodically adjust number of defrost cycles or duration of each defrost cycle to accommodate these varying conditions.**

11.2.2. Every 6 months

- Check refrigeration system for charge level, oil level, and any evidence of leaks.
- Tighten all electrical connections.
- Check operation of control system and proper functioning of defrost solenoids, drain line heaters, thermostats, etc.
- Check that all safety controls are operating appropriately.

11.3. Evaporator Maintenance Schedule (recommended maximum time periods)

11.3.1. Every 6 months

- Clean the coil surface.*
- Inspect defrost drain pan. Clean if necessary. Check for proper drainage.
- For Water Defrost, inspect water defrost distribution pans. Clean if necessary.
- Inspect all insulated supply and drain lines.
- Check all wiring.
- Check all motors and fans, tightening when necessary all motor mounting bolts and fan set screws.

***NOTICE: Do not use alkaline detergents on Aluminum coil surfaces, as corrosion may result and cause refrigerant containment failure.**

11.4. Replacement Parts

- 11.4.1. Replacement parts which are covered under the conditions of Colmac Coil's warranty (see Limited Warranty) will be reimbursed at the part cost only. For replacement parts, warranted or otherwise, contact Colmac Coil directly. When contacting Colmac Coil with the explanation of failure, have the complete model number, serial number, date of installation, and date of failure at hand.

11.5. Troubleshooting

| SYMPTOM | POSSIBLE CAUSE | POSSIBLE SOLUTION |
|---|---|---|
| 1. Coil not clearing of frost during defrost cycle. | <ol style="list-style-type: none"> 1. Insufficient number of defrost cycles. 2. Insufficient time for each defrost cycle. 3. Hot Gas refrigerant pressure too low. 4. Defective timer or pressure regulator. 5. Excessive air/moisture infiltration resulting in unreasonably high frost load. 6. Fan still operating during defrost. | <ol style="list-style-type: none"> 1. Adjust timer for more defrost cycles. 2. Adjust for increased defrost duration. 3. Adjust pressure regulator/back pressure regulator for increased pressure. Check condenser fans/pumps for proper operation. 4. Replace timer/regulator. 5. Consider some form of air/moisture infiltration mitigation, i.e. dock conditioning, air curtains, improved doors 6. Cycle fans off during defrost. Check defrost timer or other fan control device for proper operation. |
| 2. Ice building in drainpan. | <ol style="list-style-type: none"> 1. Drain line plugged. 2. Drain line not sloped as required. 3. Unit Cooler not level. 4. Drain line heater not operating adequately. 5. Defective defrosting timer/thermostat/pressure regulator. 6. Hot Gas Piping not adequately supported, forcing hot gas loop away from drainpan. 7. Improper piping and/or inadequate flow of hot gas to pan. 8. Steam created during defrost is condensing above unit and dripping/freezing onto unheated areas of evaporator. | <ol style="list-style-type: none"> 1. Clean drain line. 2. Adjust as necessary. 3. Adjust as necessary. 4. Repair or replace as necessary. 5. Repair or replace as necessary. 6. Add additional hot gas piping support. 7. Increase hot gas flow to drain pan. 8. See Symptom #4 below. |
| 3. Uneven coil frosting. | <ol style="list-style-type: none"> 1. Unit Cooler located too close to door or other room opening. 2. Unit Cooler not level, causing uneven loading. 3. Defrost cycle time too short. 4. Fans not operating correctly. 5. Liquid supply not sufficient to properly feed unit. 6. Liquid control device not open or large enough. | <ol style="list-style-type: none"> 1. Relocate as necessary. 2. Adjust as necessary. 3. Increase duration of each defrost cycle. 4. Check fans and fan motors for proper operation. Replace or repair as needed. 5. Increase refrigerant supply to unit cooler. Check strainers, expansion valves, etc. 6. Correct or replace as necessary. |

| SYMPTOM | POSSIBLE CAUSE | POSSIBLE SOLUTION |
|---|---|--|
| 4. Ice accumulating on ceiling above evaporator or in air section or around motors, fans, and fan venturis. | <ol style="list-style-type: none"> 1. Defrost cycle time too long, "overcooking" the unit. 2. Too many defrosts cycles during a 24-hour period. 3. Defective defrosting timer/thermostat/pressure regulator. | <ol style="list-style-type: none"> 1. Decrease duration of each defrost cycle. 2. Decrease number of defrost cycles. 3. Repair or replace as necessary. |
| 5. Elevated Room Temperature | <ol style="list-style-type: none"> 1. Room thermostat set incorrectly. 2. Low refrigerant charge. 3. Airflow restricted to evaporator. 4. Undersized evaporators for required heat load. 5. Fan motors not operating. 6. Insufficient refrigerant flow. | <ol style="list-style-type: none"> 1. Check thermostat and adjust appropriately. 2. Add refrigerant. 3. Check evaporator for airflow blockage, including ice buildup, foreign matter, etc. Clean as necessary. 4. If heat load exceeds design conditions, evaporator operating conditions may have to be changed, or evaporators will need to be added to the conditioned space. 5. Check fans and fan motors for proper operation. Replace or repair as needed. 6. Check strainers, hand expansion valves, etc. |
| 6. Frequent Fan and/or Motor Failure | <ol style="list-style-type: none"> 1. Unit cycling too frequently, causing excessive fatigue related wear and tear. 2. Check quality of power supply. | <ol style="list-style-type: none"> 1. Limit number of cycles, whether it is for capacity control or defrost operation. 2. Install power conditioning equipment, phase failure relays, etc. |
| 7. Insufficient Airthrow | <ol style="list-style-type: none"> 1. Unit too close to wall, product, etc. for proper return air supply to fan. 2. Unit obstructed with ice blockage. 3. No airthrow straightener specified with unit purchase. 4. Fan and/or fan motors not operating correctly. 5. VFD fan speed too low. | <ol style="list-style-type: none"> 1. Relocate unit to allow for unobstructed airflow. 2. See Symptoms 1-4 above. 3. Purchase optional airthrow straighteners from evaporator manufacturer. 4. Check fans and fan motors for proper operation. Replace or repair as needed. 5. Increase fan speed. |

FIGURE 1
UNIT RIGGING
AR UNIT COOLER

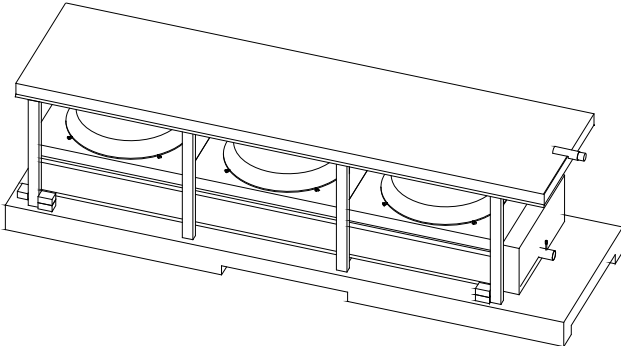

Step 1: Remove outer crating from unit.

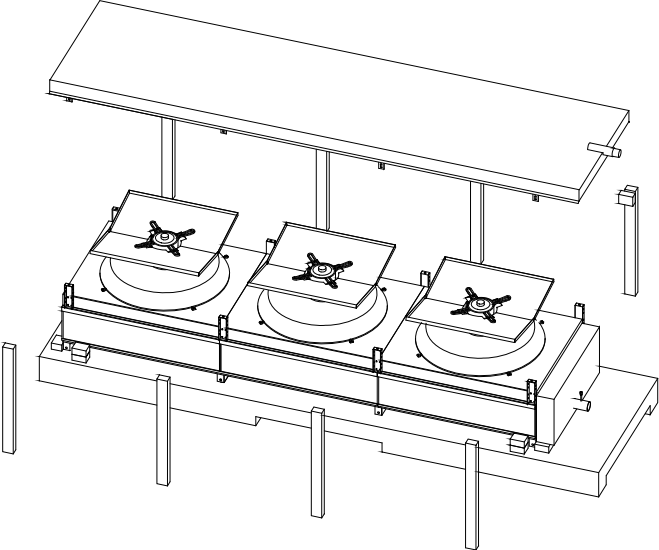

Step 2: Remove drainpan and support pieces from the top of the unit.

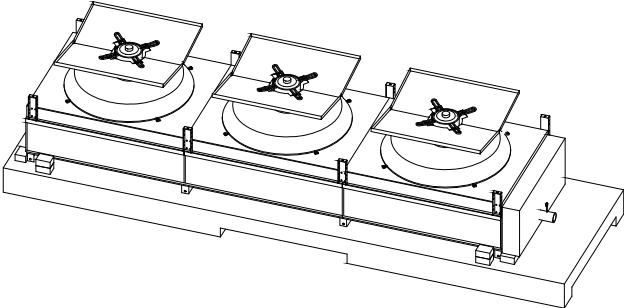

Step 3: Hang the unit using the skid.

FIGURE 1
UNIT RIGGING
AR UNIT COOLER

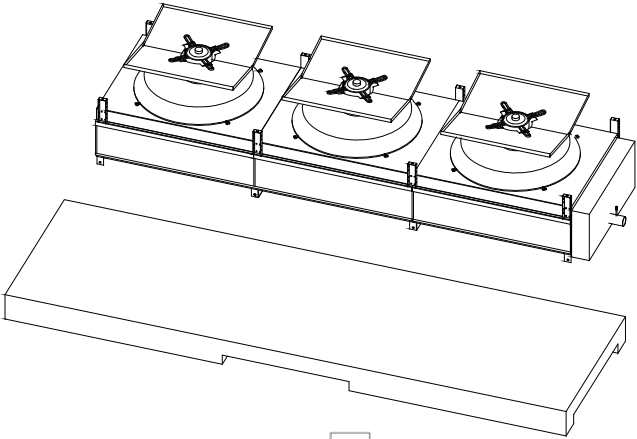

Step 4: Remove the skid from the unit.

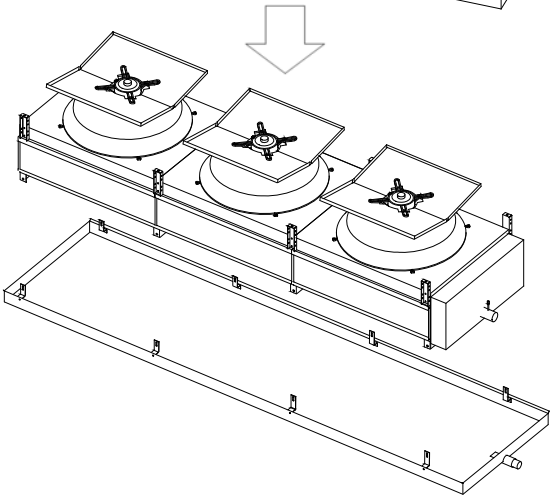

Step 5: Raise drainpan up to unit.

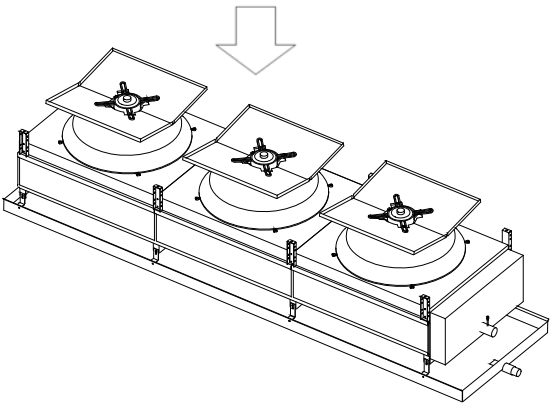

Step 6: Attach drainpan to the bottom of unit.

FIGURE 2
UNIT RIGGING
ICH UNIT COOLER

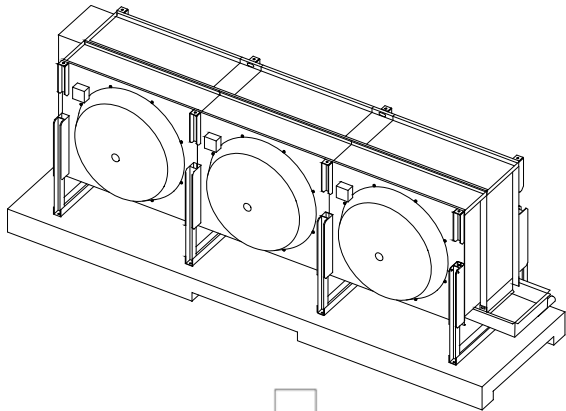

Step 1: Remove skidded unit from truck. Lift unit into place on skid.

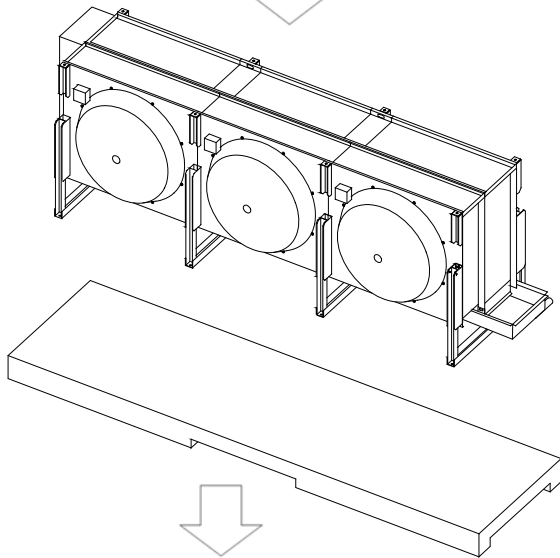

Step 2: Remove skid from unit.

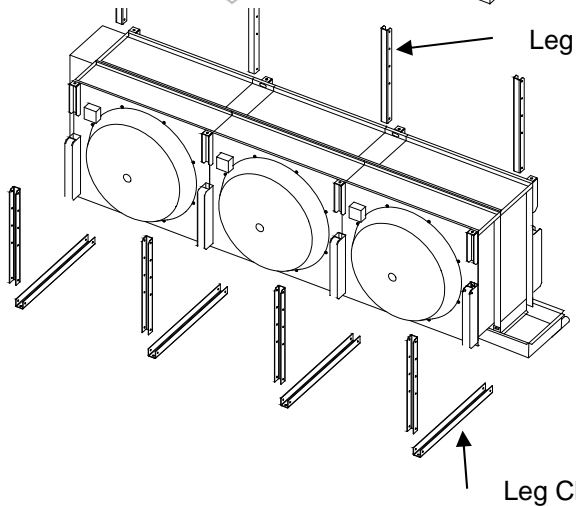

Step 3: Legs and leg channels can be removed.

FIGURE 3
UNIT RIGGING
ICL UNIT COOLER

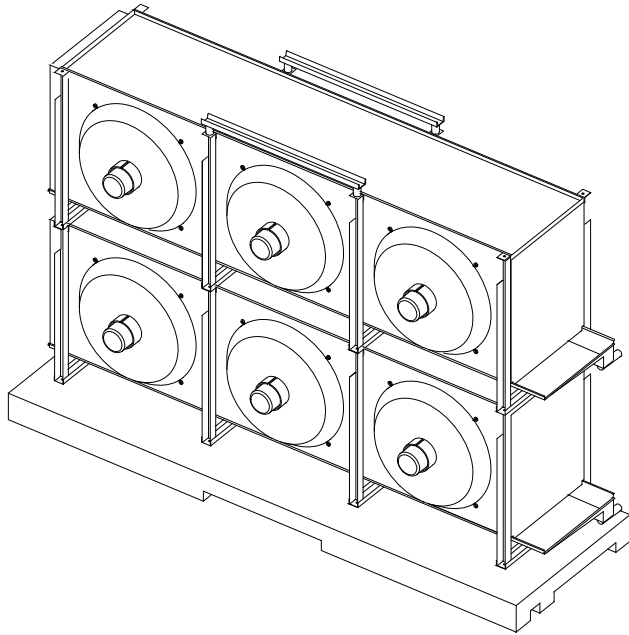

Step 1: Units arrive on truck stacked two high. Unload units from truck.

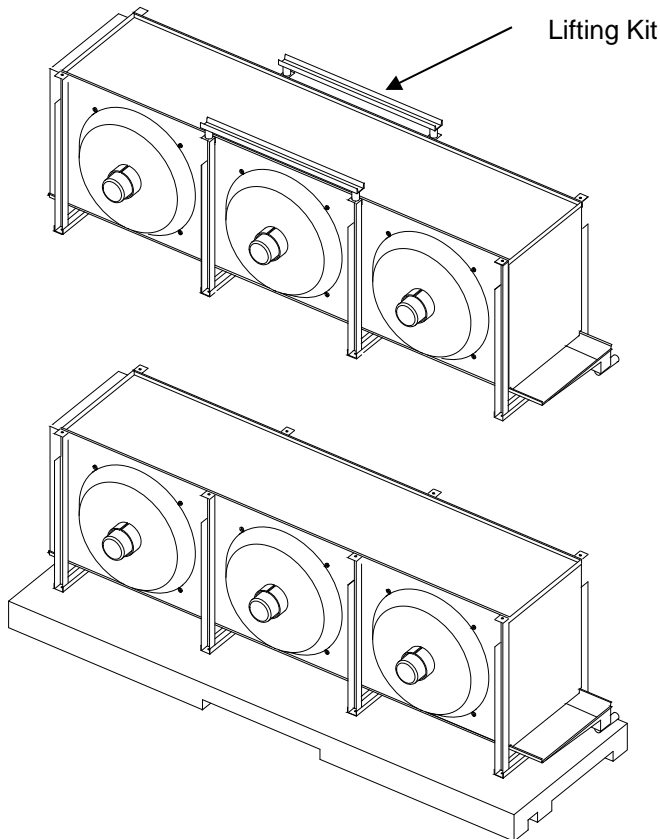

Step 2: Unbolt and remove the top unit from the bottom using the lifting kit attached to the hanger/legs. Place the top unit off to the side.

FIGURE 3
UNIT RIGGING
ICL UNIT COOLER

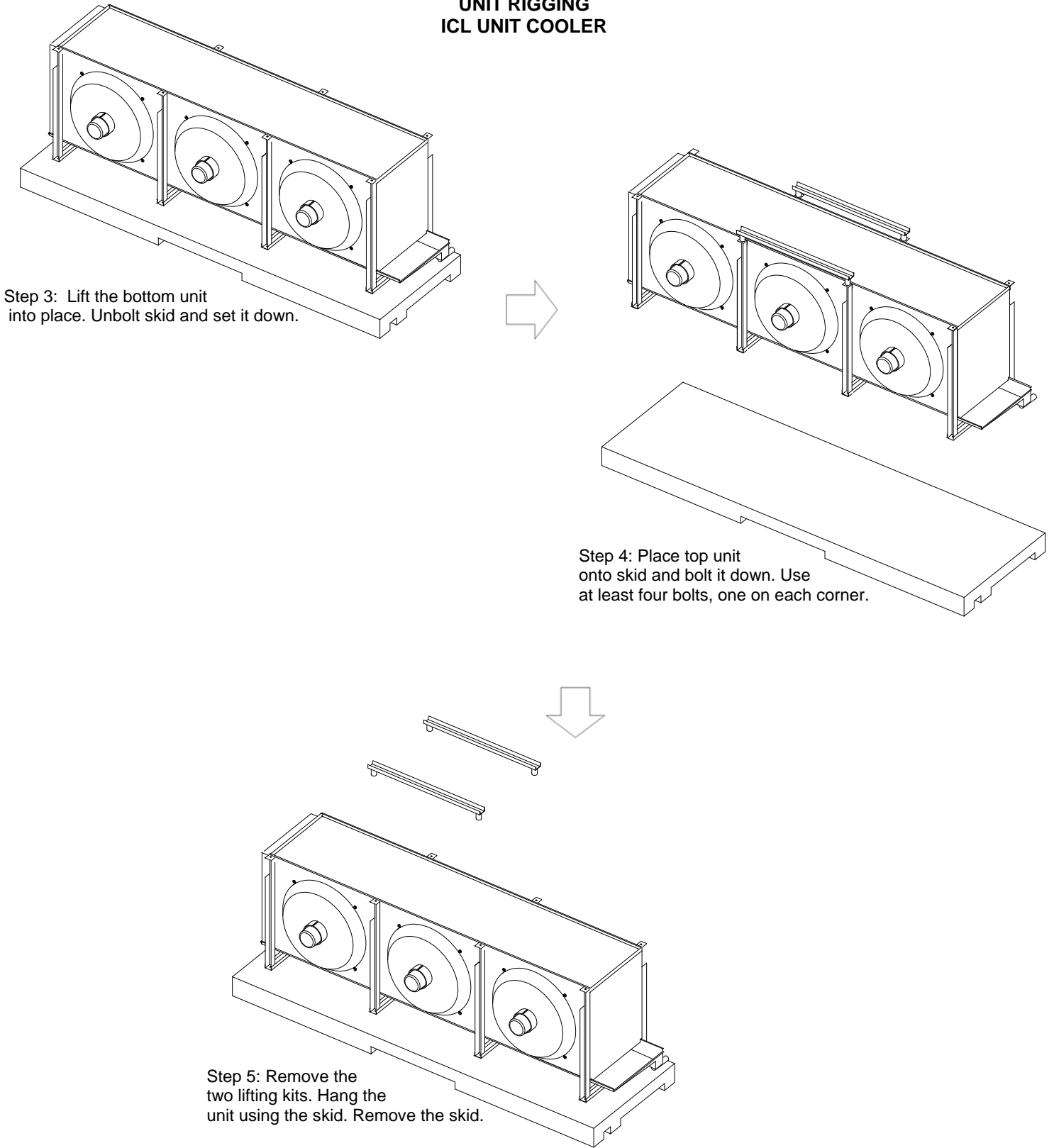
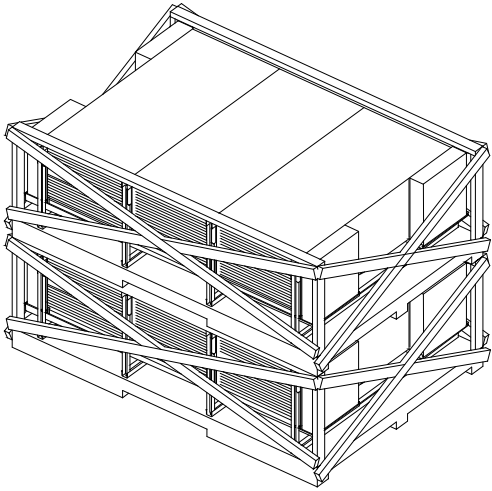
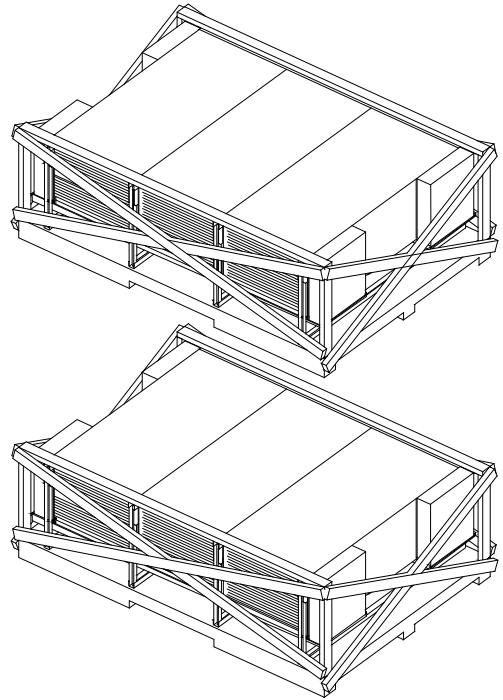

FIGURE 4
UNIT RIGGING
LV UNIT COOLER



Step 1: Units arrive stacked, but individually skidded.



Step 2: Remove units from the truck, one at a time.

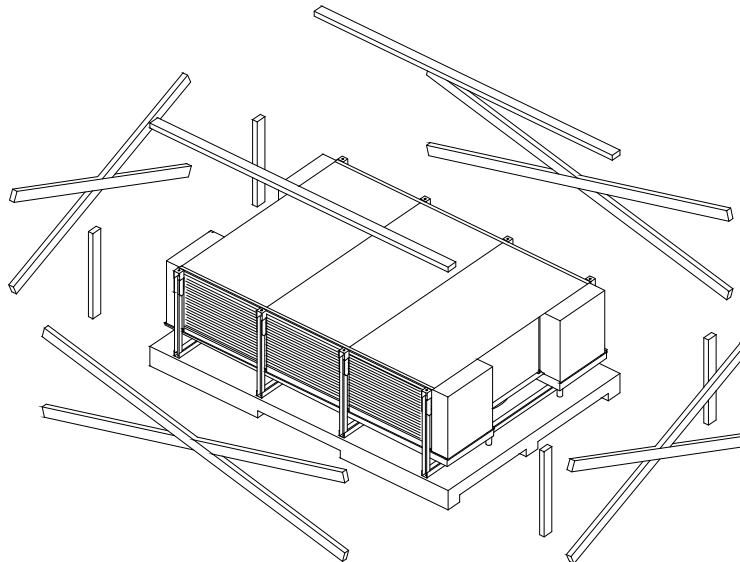

Step 3: Remove 2" x 4" wood shipping braces.

FIGURE 4
UNIT RIGGING
LV UNIT COOLER

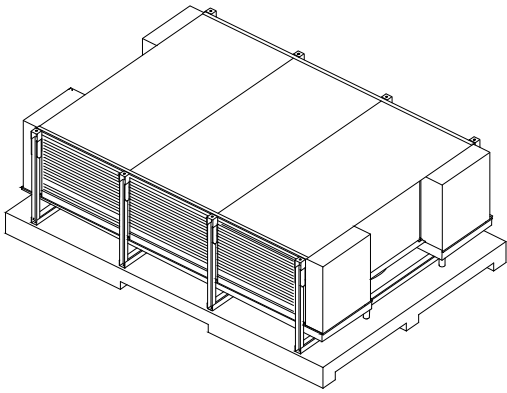

Step 4: Lift unit into place on skid.

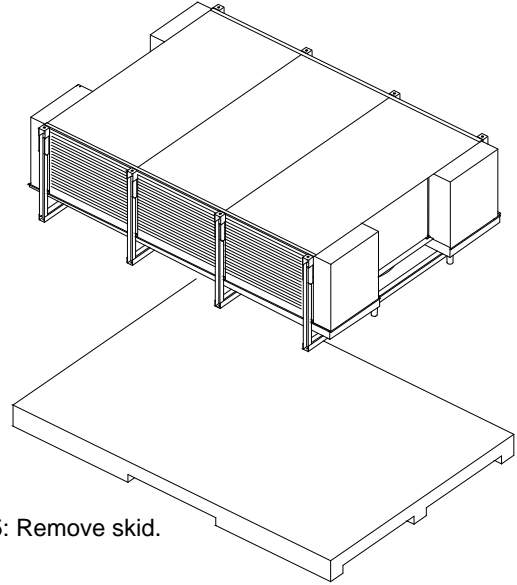

Step 5: Remove skid.

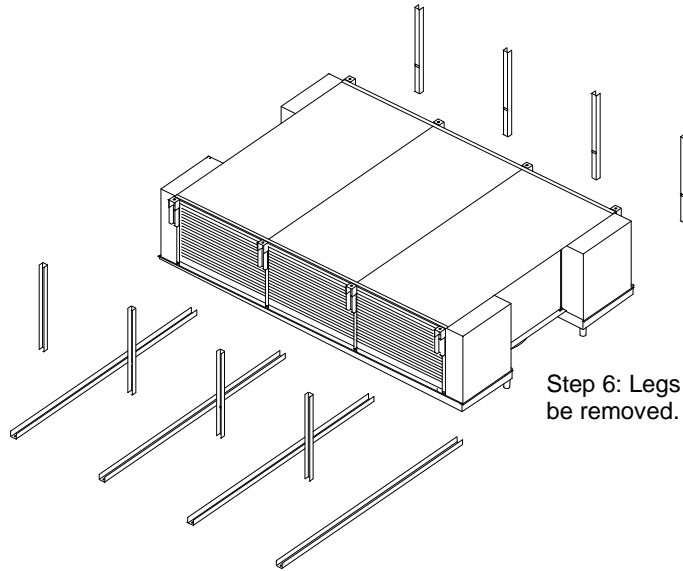

Step 6: Legs and leg channels can be removed.

FIGURE 5
WATER DEFROST PIPING
AR UNIT COOLER

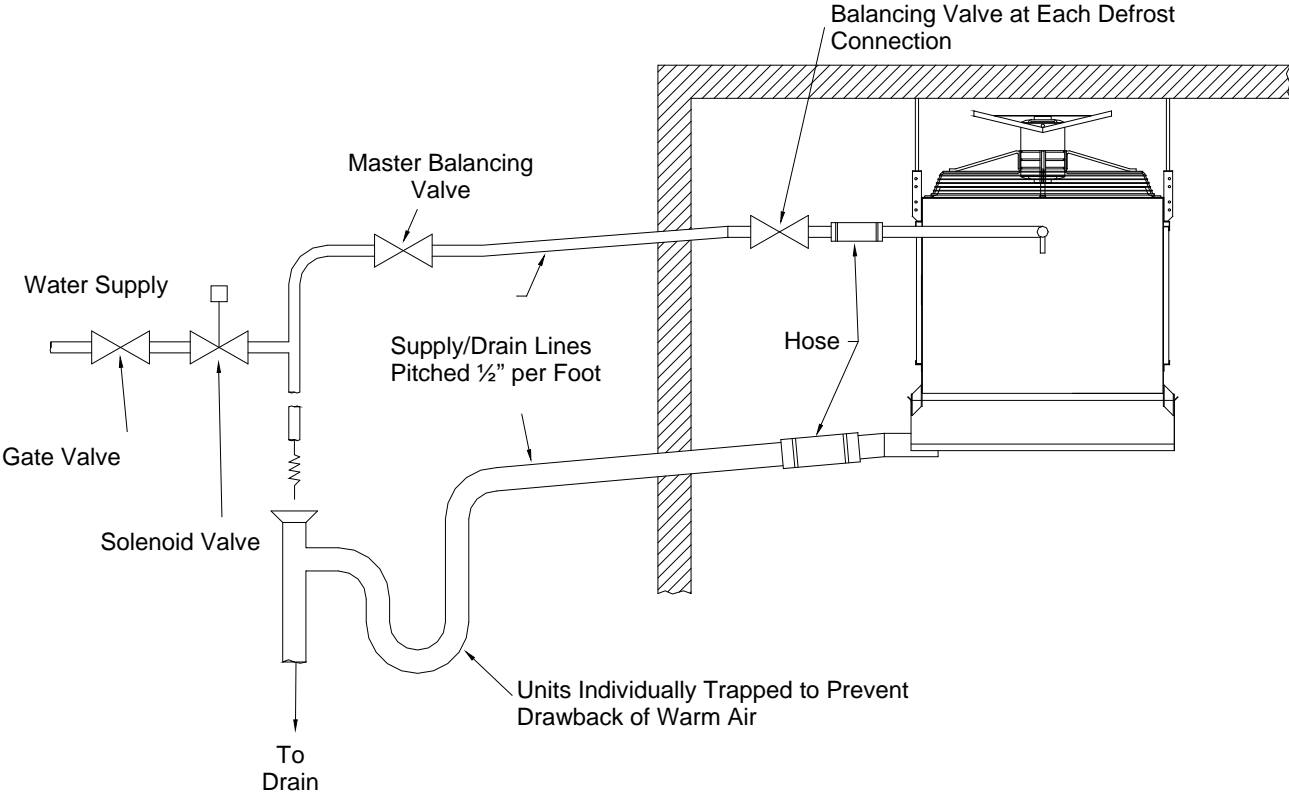

FIGURE 6
WATER DEFROST PIPING
ICH UNIT COOLER

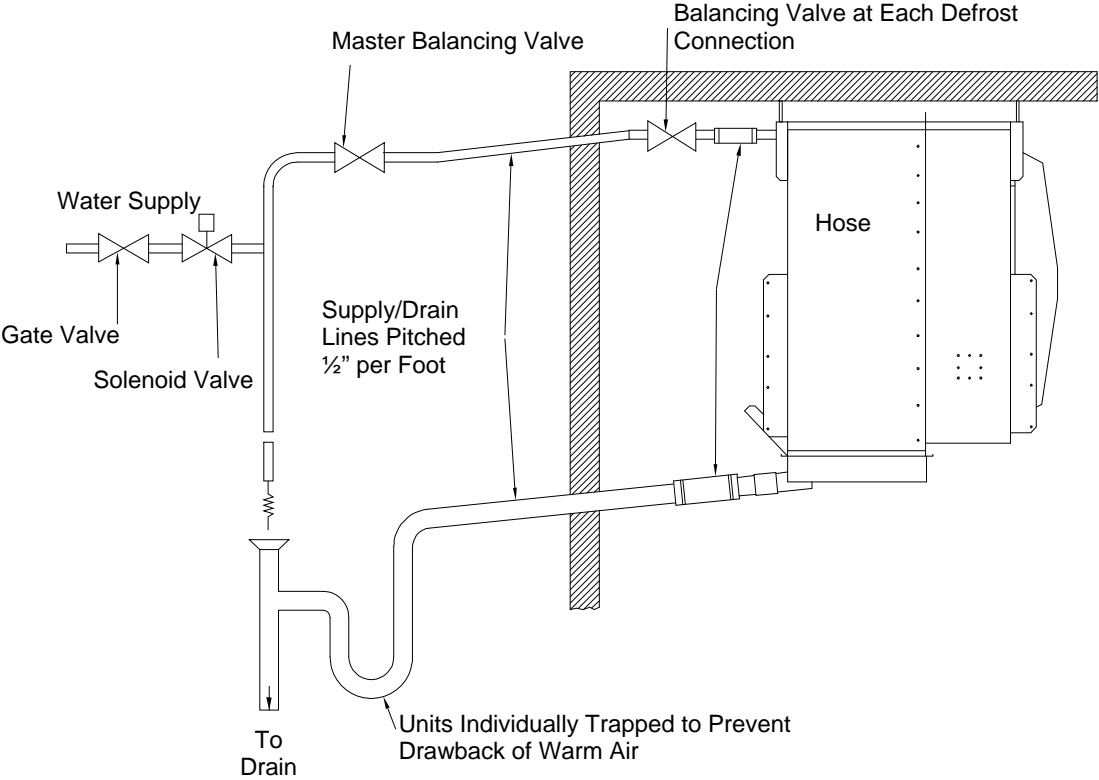

FIGURE 7
WATER DEFROST PIPING
ICL UNIT COOLER

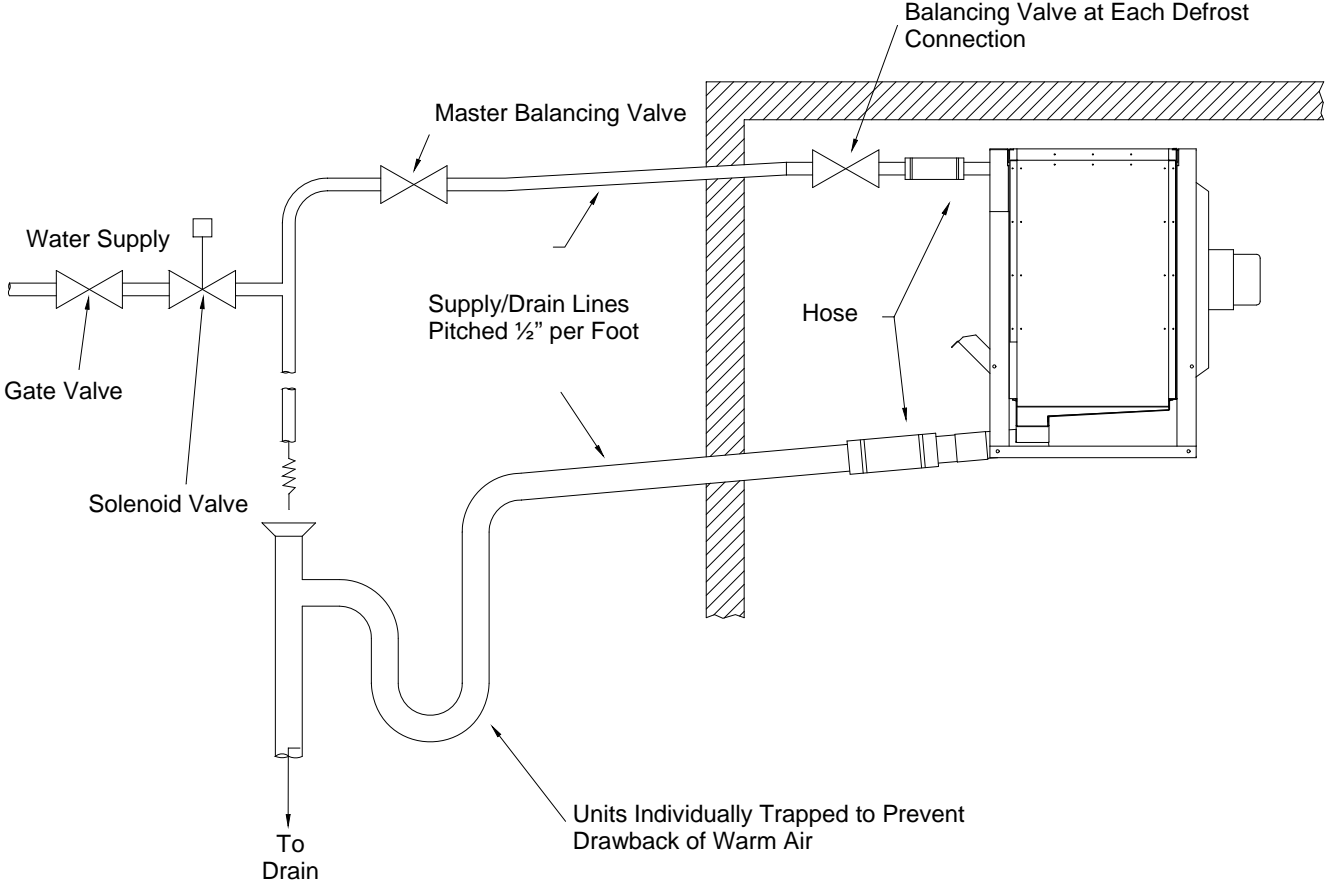

FIGURE 8

WATER DEFROST PIPING
LV UNIT COOLER

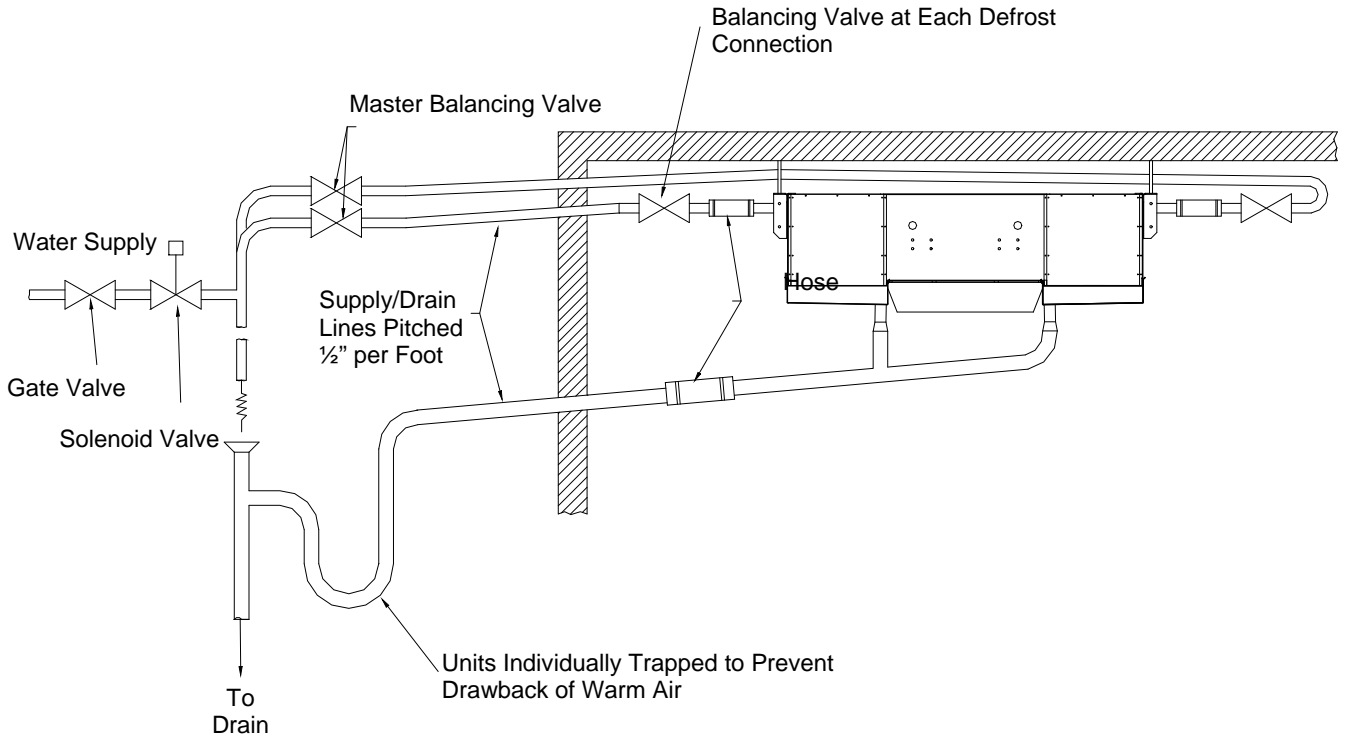

FIGURE 9

DIELECTRIC FLANGE UNION

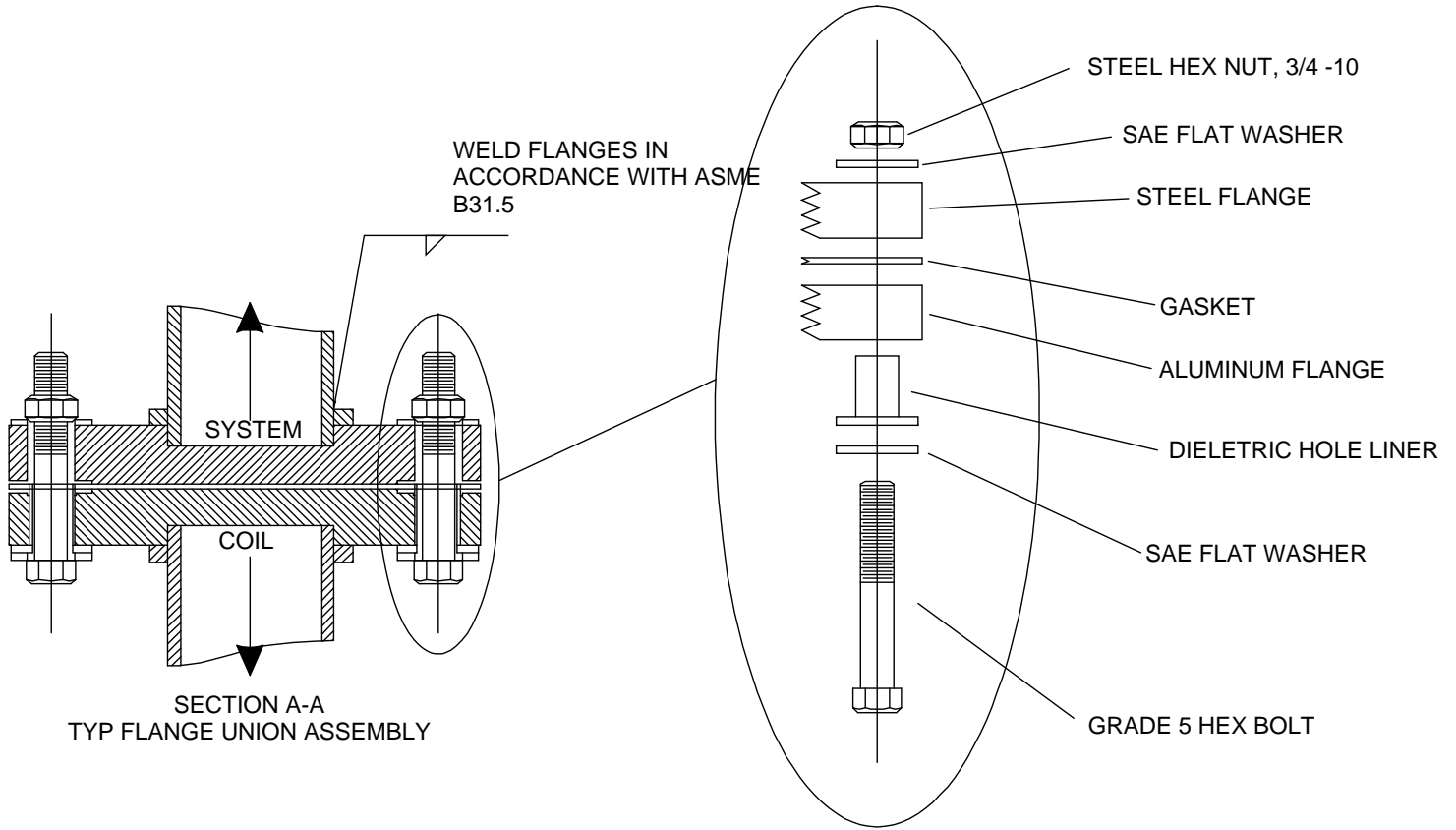

FIGURE 10

BIMETTALIC COUPLER

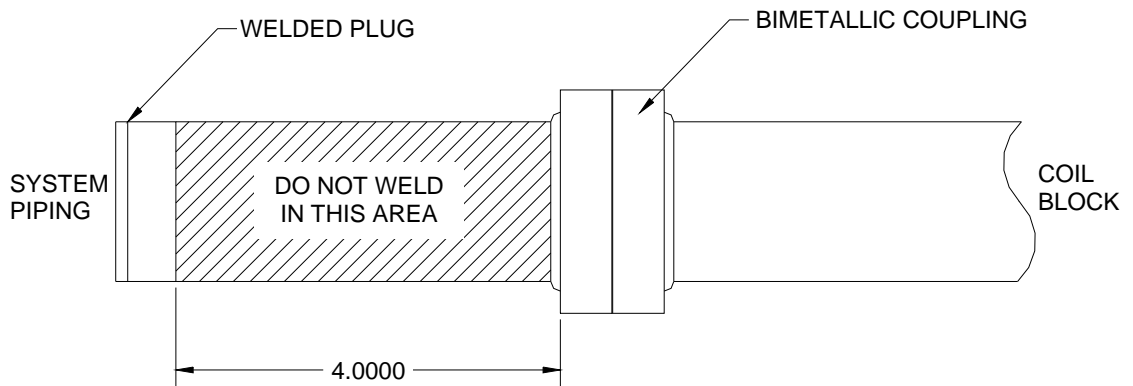
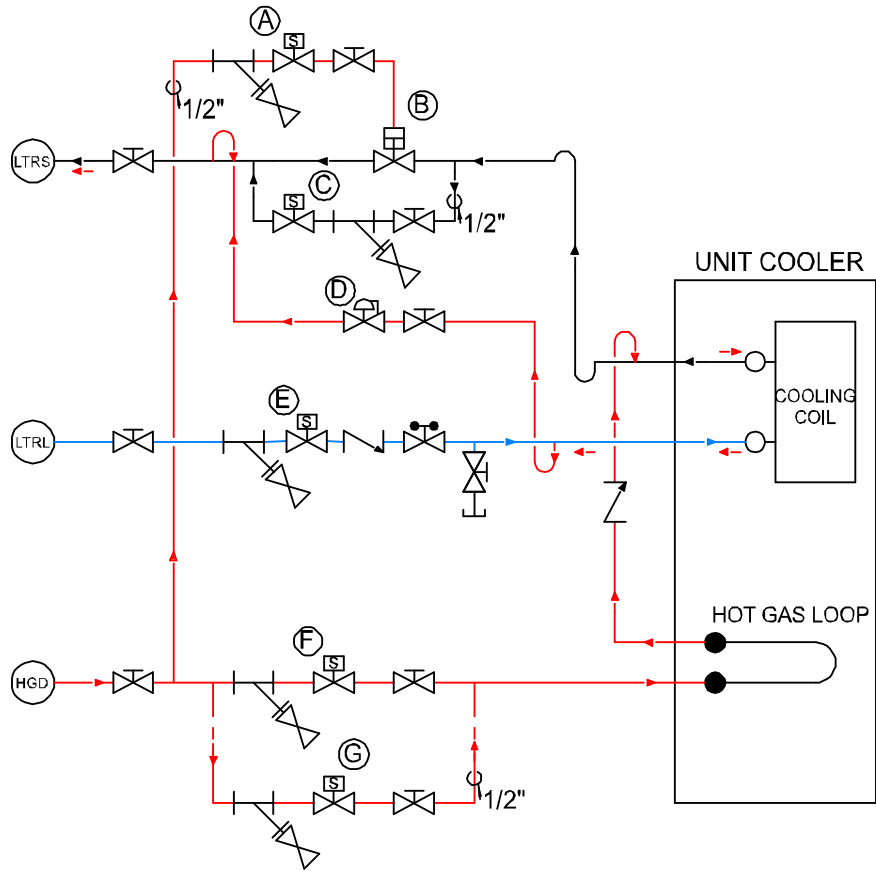













FIGURE 11

**HOT GAS DEFROST PIPING
RECIRCULATED BOTTOM FEED EVAPORATOR**



-  HAND EXPANSION VALVE
-  GLOBE VALVE
-  GAS POWERED SUCTION STOP VALVE
-  SOLENOID VALVE
-  DEFROST PRESSURE REGULATOR
-  CHECK VALVE
-  STRAINER, BLOW-OFF
-  DRAIN
-  HOT GAS FLOW
-  SATURATED LIQUID FLOW
-  SATURATED LIQUID & VAPOR FLOW

- HGD HOT GAS DEFROST SUPPLY
- LTRS LOW-TEMP RECIRCULATED SUCTION
- LTRL LOW-TEMP RECIRCULATED LIQUID
- A PILOT SOLENOID VALVE (S8 OR HS8)
- B GAS POWERED SUCTION STOP VALVE (CK2 OR HCK2)
- C EQUALIZING BLEED VALVE (S8 OR HS8)
- D DEFROST RELIEF REGULATOR (A4AK OR HA4AK)
- E LIQUID SOLENOID (S4A OR HS4A)
- F HOT GAS SOLENOID (S4A OR HS4A)
- G SOFT START HOT GAS SOLENOID (S8 OR HS8) (RECOMENDED FOR EVAPORATORS OF 15 TONS OR GREATER COOLING CAPACITY)

FIGURE 12

**HOT GAS DEFROST PIPING
RECIRCULATED TOP FEED EVAPORATOR**

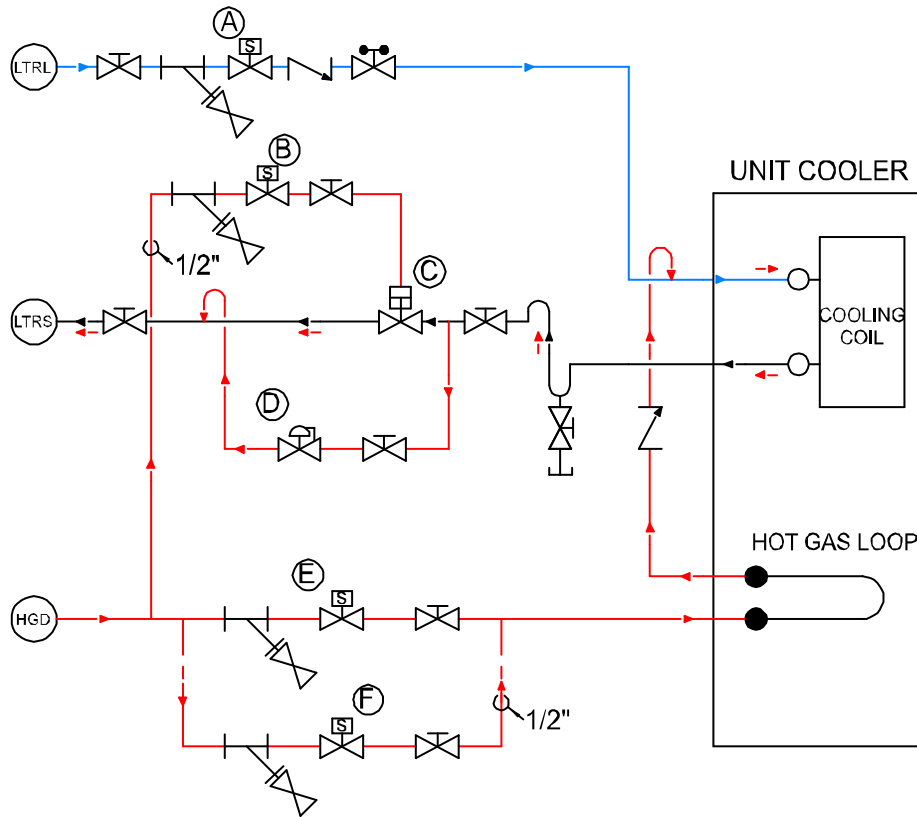

- | | | | |
|--|--------------------------------|------|---|
| | HAND EXPANSION VALVE | HGD | HOT GAS DEFROST SUPPLY |
| | GLOBE VALVE | LTRS | LOW-TEMP RECIRCULATED SUCTION |
| | GAS POWERED SUCTION STOP VALVE | LTRL | LOW-TEMP RECIRCULATED LIQUID |
| | SOLENOID VALVE | A | LIQUID SOLENOID (S4A OR HS4A) |
| | DEFROST PRESSURE REGULATOR | B | PILOT SOLENOID VALVE (S8 OR HS8) |
| | CHECK VALVE | C | GAS POWERED SUCTION STOP VALVE (CK2 OR HCK2) |
| | STRAINER, BLOW-OFF | D | DEFROST RELIEF REGULATOR W/ WIDE OPENING FEATURE FOR EQUALIZING (A4A OR HA4A) |
| | DRAIN | E | HOT GAS SOLENOID (S4A OR HS4A) |
| | HOT GAS FLOW | F | SOFT START HOT GAS SOLENOID (S8 OR HS8) (RECOMENDED FOR EVAPORATORS OF 15 TONS OR GREATER COOLING CAPACITY) |
| | SATURATED LIQUID FLOW | | |
| | SATURATED LIQUID & VAPOR FLOW | | |

NOTE 1: DEFROST PRESSURE REGULATOR OPERATES WIDE-OPEN DURING NORMAL OPERATION, AND OPERATED AS REGULATOR DURING DEFROST.

FIGURE 13

**HOT GAS DEFROST PIPING
DIRECT EXPANSION EVAPORATOR**

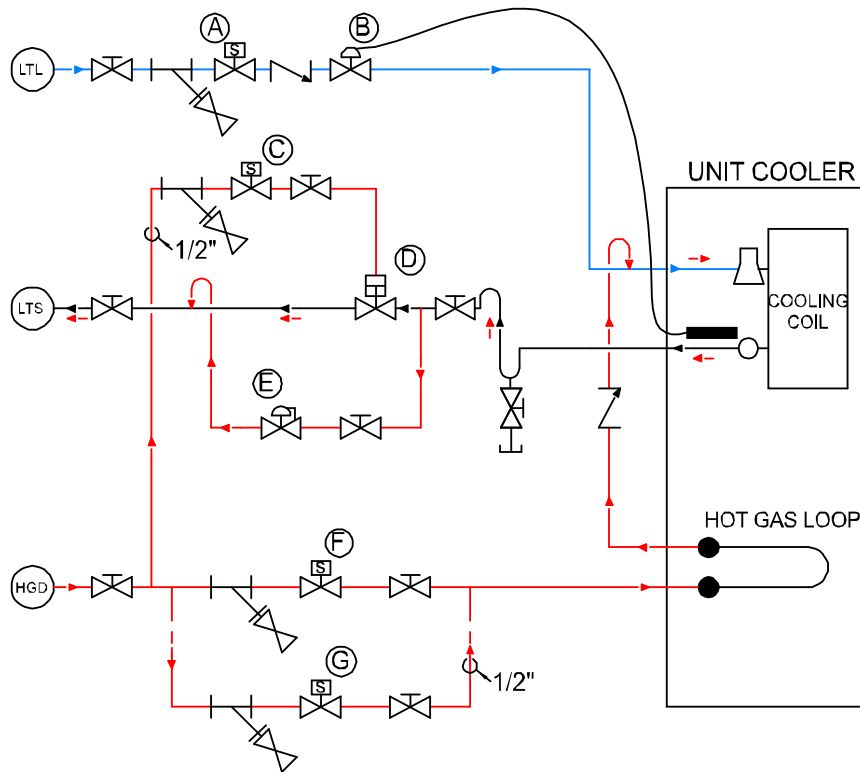

- | | | | |
|--|--------------------------------|-----|---|
| | HAND EXPANSION VALVE | HGD | HOT GAS DEFROST SUPPLY |
| | GLOBE VALVE | LTS | LOW-TEMP SUCTION |
| | GAS POWERED SUCTION STOP VALVE | LTL | LOW-TEMP LIQUID |
| | SOLENOID VALVE | A | LIQUID SOLENOID (S4A OR HS4A) |
| | DEFROST PRESSURE REGULATOR | B | THERMAL EXPANSION VALVE |
| | THERMAL EXPANSION VALVE | C | PILOT SOLENOID VALVE (S8 OR HS8) |
| | CHECK VALVE | D | GAS POWERED SUCTION STOP VALVE (CK2 OR HCK2) |
| | STRAINER, BLOW-OFF | E | DEFROST RELIEF REGULATOR W/ WIDE OPENING FEATURE FOR EQUALIZING (A4AB OR HA4AB) |
| | DRAIN | F | HOT GAS SOLENOID (S4A OR HS4A) |
| | HOT GAS FLOW | G | SOFT START HOT GAS SOLENOID (S8 OR HS8) (RECOMENDED FOR EVAPORATORS OF 15 TONS OR GREATER COOLING CAPACITY) |
| | SATURATED LIQUID FLOW | | |
| | SUPERHEATED VAPOR FLOW | | |

NOTE 1: DEFROST PRESSURE REGULATOR OPERATES WIDE-OPEN DURING NORMAL OPERATION, AND OPERATED AS REGULATOR DURING DEFROST.

FIGURE 14

**HOT GAS DEFROST PIPING
GRAVITY FLOODED EVAPORATOR**

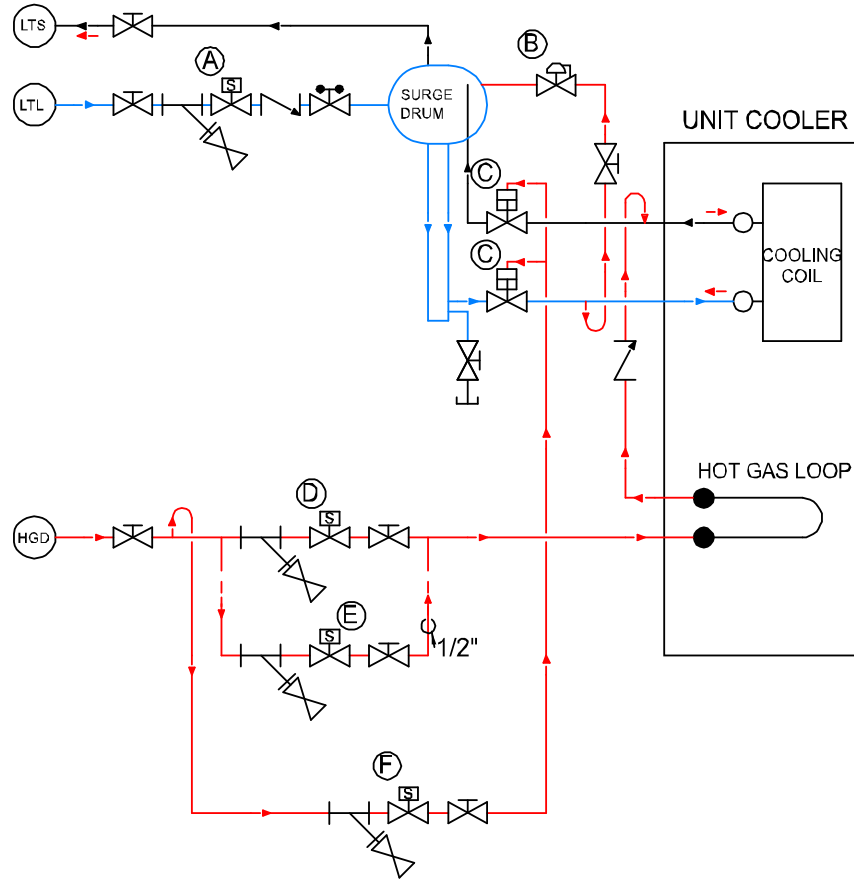

- | | | | |
|--|--------------------------------|-----|---|
| | HAND EXPANSION VALVE | HGD | HOT GAS DEFROST SUPPLY |
| | GLOBE VALVE | LTS | LOW-TEMP SUCTION |
| | GAS POWERED SUCTION STOP VALVE | LTL | LOW-TEMP LIQUID |
| | SOLENOID VALVE | A | LIQUID SOLENOID (S4A OR HS4A) |
| | DEFROST PRESSURE REGULATOR | B | DEFROST RELIEF REGULATOR W/ WIDE OPENING FEATURE FOR EQUALIZING (A4AB OR HA4AB) |
| | CHECK VALVE | C | GAS POWERED SUCTION STOP VALVE(CK2 OR HCK2) |
| | STRAINER, BLOW-OFF | D | HOT GAS SOLENOID (S4A OR HS4A) |
| | DRAIN | E | SOFT START HOT GAS SOLENOID (S8 OR HS8) (RECOMENDED FOR EVAPORATORS OF 15 TONS OR GREATER COOLING CAPACITY) |
| | HOT GAS FLOW | F | PILOT SOLENOID VALVE (S8 OR HS8) |
| | SATURATED LIQUID FLOW | | |
| | SATURATED LIQUID & VAPOR FLOW | | |

FIGURE 15
ELECTRICAL DIAGRAM
MOTORS

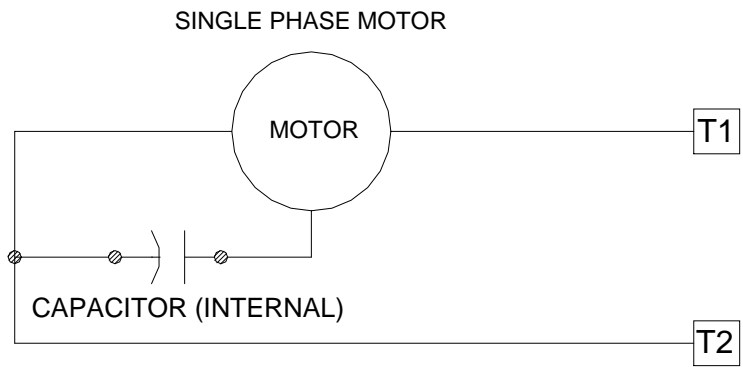
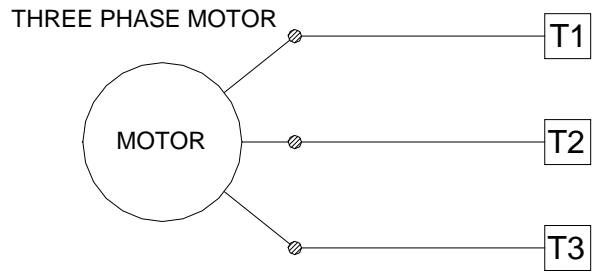



Colmac reserves the right to change product design and specifications without notice.

For more information on Colmac products call us at 1-800-845-6778 or visit us online at:

WWW.COLMACCOIL.COM
