

BACKGROUND:

As anyone who has been around electric defrost evaporators knows, electric heating elements can “walk” or “creep” out of coil tubes over time. The re-freezing of liquid water onto the surface of the heating element at the end of the defrost cycle generates extremely powerful forces acting to slowly move the heating element along the length of the vacant space in the heat exchanger. If the heating elements are allowed to creep or walk out of the heat exchanger, damage to electrical wiring and to the element itself will result.

BENEFITS:

- Restrains movement of defrost elements. No more “creeping”!
- Re-centers elements in the coil at the start of every defrost cycle
- Prevents damage to elements, wiring, and coil return bends
- Extends the life of defrost elements
- Simplifies wiring (device is self-grounding)
- Standard on all Colmac electric defrost evaporators
- Retrofit of existing evaporators is possible

“HOW DOES IT WORK?”

The Colmac Self-Positioning Defrost Element System is simple!

It works by means of a spring which is attached securely to both the heating element sheath and to the coil tubesheet. The spring allows movement of the heating element in either direction parallel to the axis of the heating element. Movement of the heating element is caused when melted frost in the form of liquid water re-freezes and bonds the heating element sheath to an adjacent heat exchanger surface at a point along the length of the heating element while the element continues to shrink as it cools to refrigerating temperature. During the next defrost cycle the defrost element heats up, ice is melted, and the spring brings the element back to its original position in the coil.

Figure 1 below shows the Colmac Self-Positioning Defrost Element System (item 20) installed in a finned-tube coil (item 12).

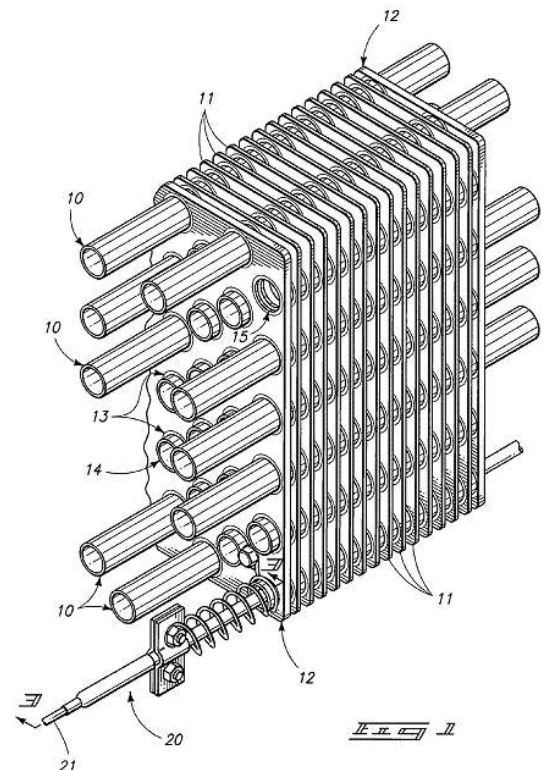

US Patent No. 7,712,327



Other Quality Products From Colmac Coil



Heating and Cooling Coils



Heat Pipes for Heat Recovery



Dry Coolers for Glycol or Gas Cooling



Custom Evaporators & Baudelot Coolers



Air Cooled Condensers

CE(PED) Certification, ASME Sec. VIII, Canadian Registration Number, UL508, Canadian Standards Association



CRN



CSA

Visit www.colmaccoil.com for more information and resources:

Product Information

Product Literature

Sales Rep Locator

North American Headquarters

Colmac Coil Manufacturing, Inc.
370 N. Lincoln St. | P.O. Box 571
Colville, WA 99114 | USA
+1.509.684.2595 | +1.800.845.6778

Midwest US Manufacturing

Colmac Coil Midwest
350 Baltimore Dr. | Paxton, IL 60957 | USA

"The Heat Transfer Experts"